

Quick Start Guide

Laptop Cooling Pad

Part Name

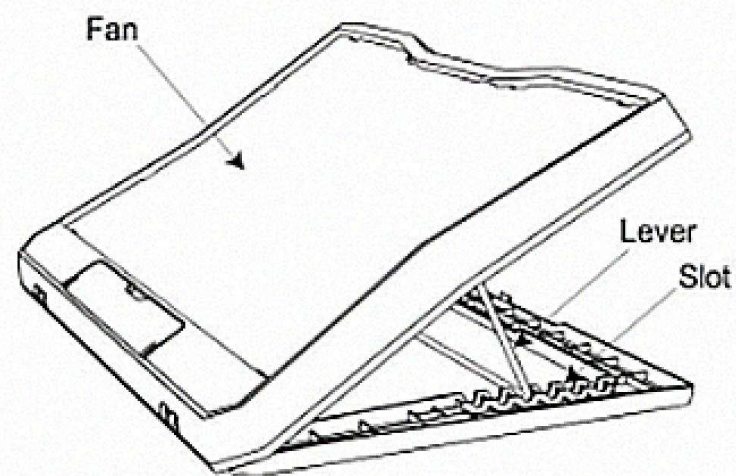
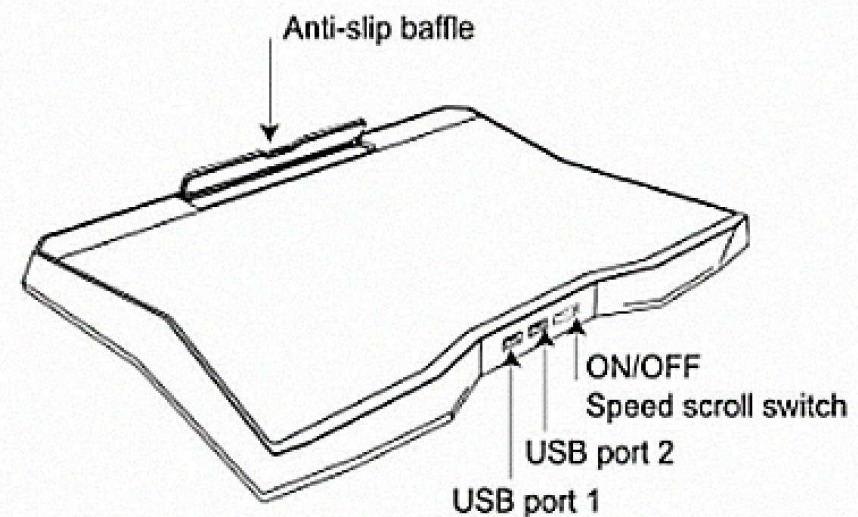

Instruction Step

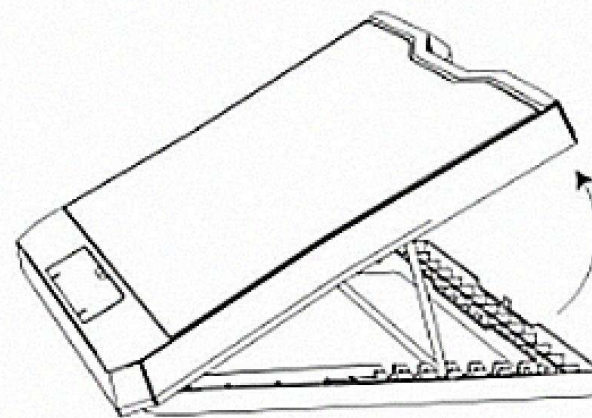

1. Open the base, adjust lever to the most comfortable position. 6 different height settings for user's requirement of better viewing angles.

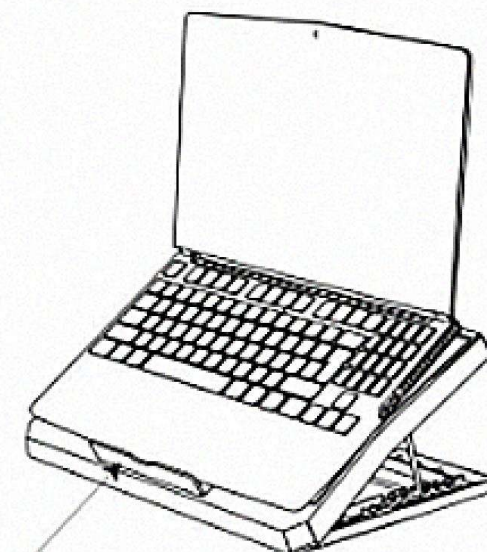

2. Open the anti-slip baffle on the front. Place your laptop or tablet PC on the cooling pad.

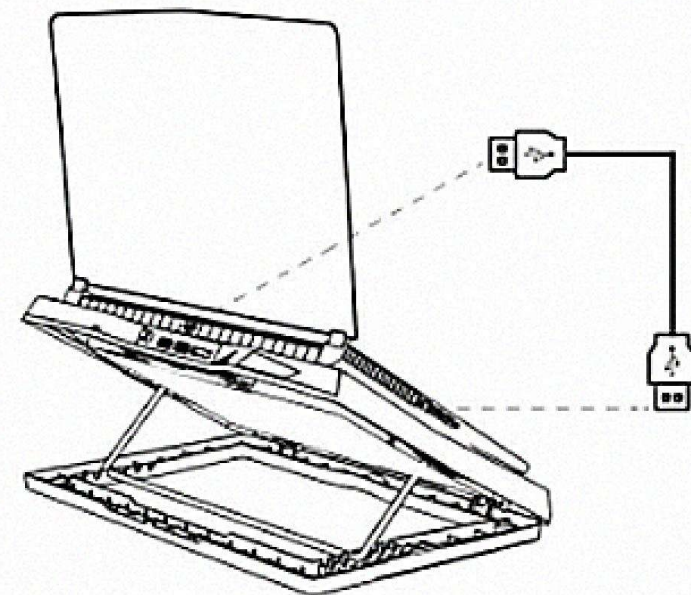

3. Turn on your laptop or tablet PC. Connect the USB cable to the device and the USB port located on the back of cooling pad.

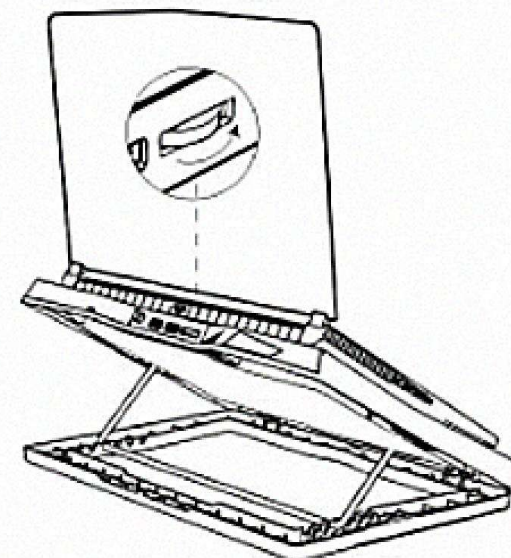

4. Use the fan speed scroll switch to turn on your cooling pad and adjust the speed of fans. (Note: Turn to the left to decrease, turn to the right to increase)

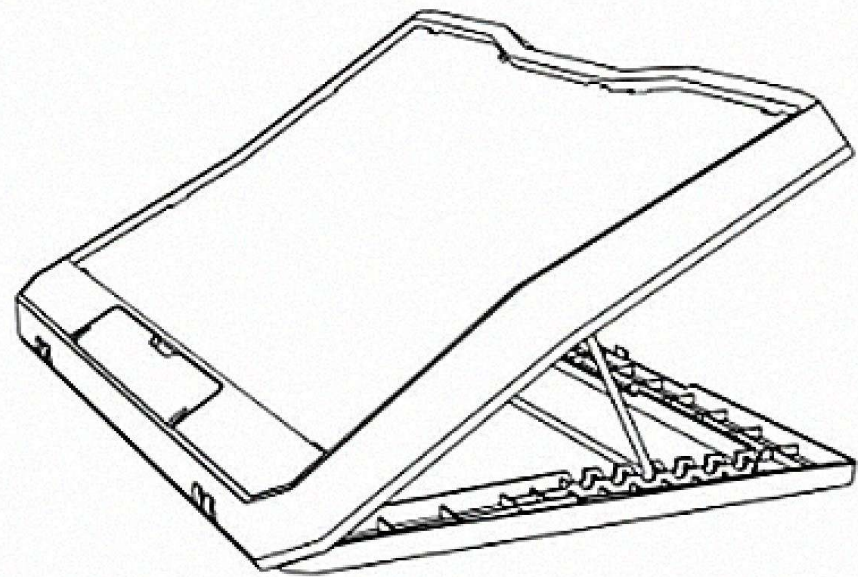

Almohadilla de enfriamiento para computadora portátil



pieza

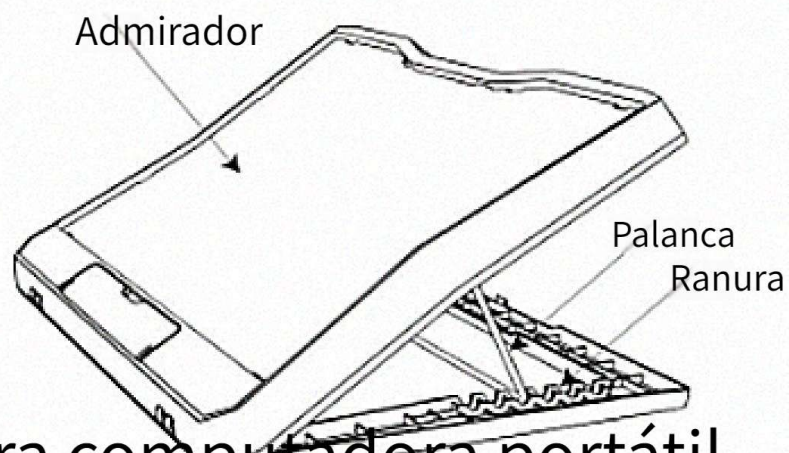
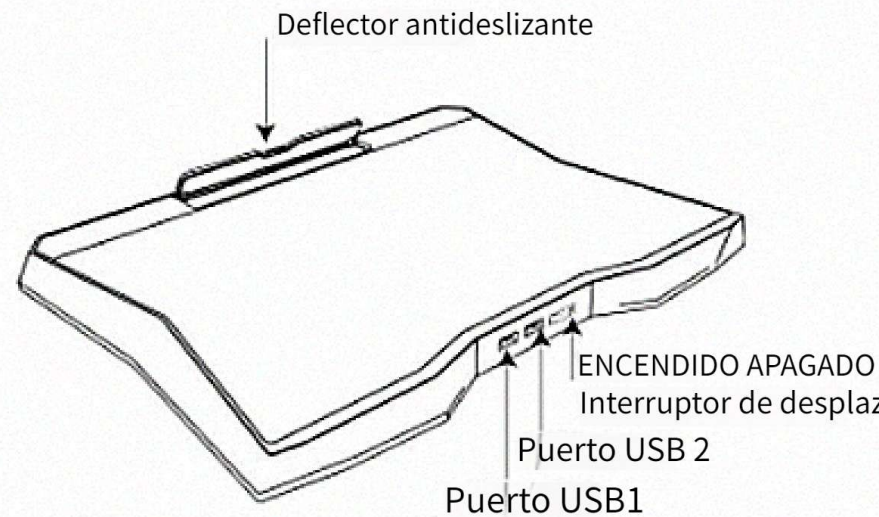

modo de instrucción

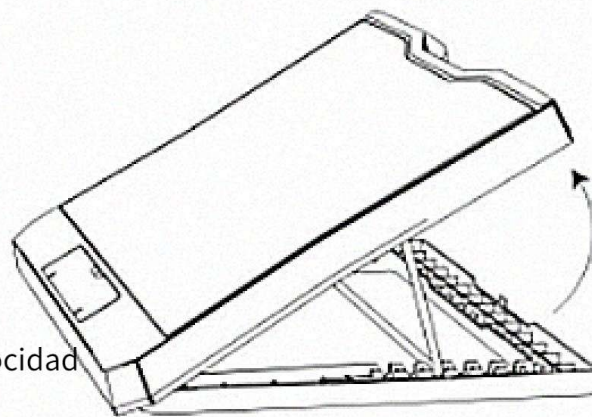

1. Abra la base, ajuste la palanca a la posición más cómoda. 6 configuraciones de altura diferentes para los requisitos del usuario de mejores ángulos de visión.

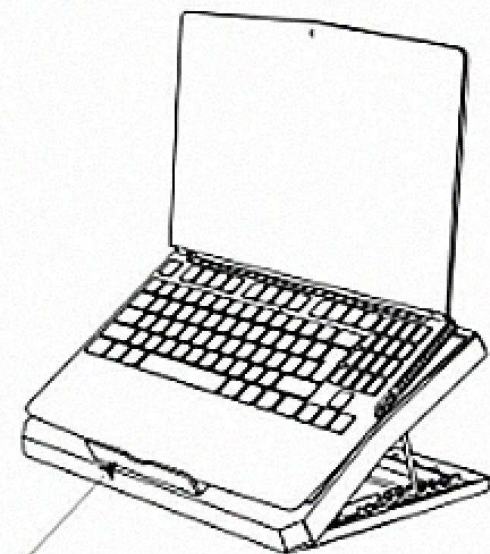

2. Abra el deflector antideslizante en la parte frontal. Coloque su computadora portátil o tableta en la almohadilla de enfriamiento.

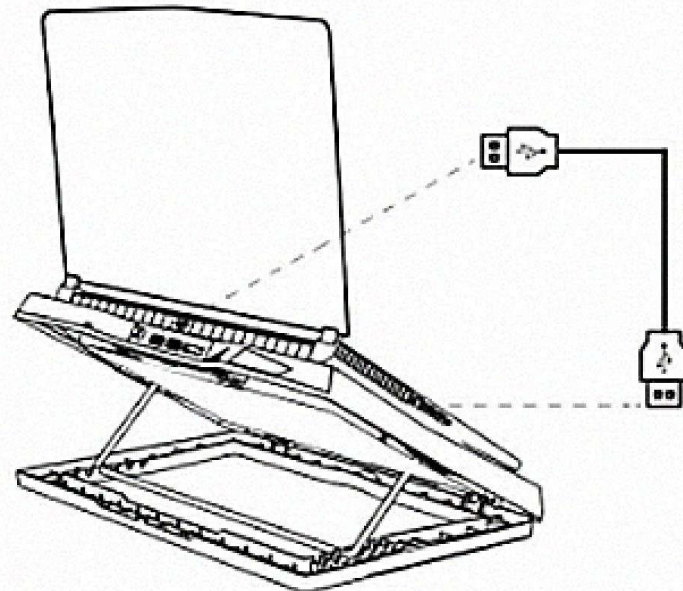

3. Encienda su computadora portátil o tableta. Conecte el cable USB al dispositivo y al puerto USB ubicado en la parte posterior de la almohadilla de enfriamiento.

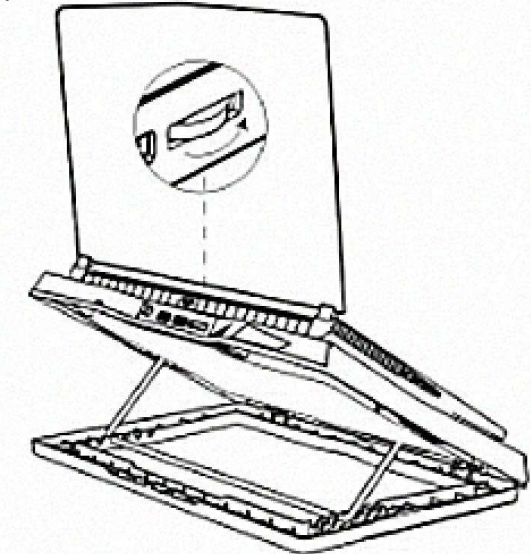

4. Utilice el interruptor de desplazamiento de velocidad del ventilador para encender su panel de enfriamiento y ajustar la velocidad de los ventiladores. (Nota: gire hacia la izquierda para disminuir; gire hacia la derecha para aumentar)

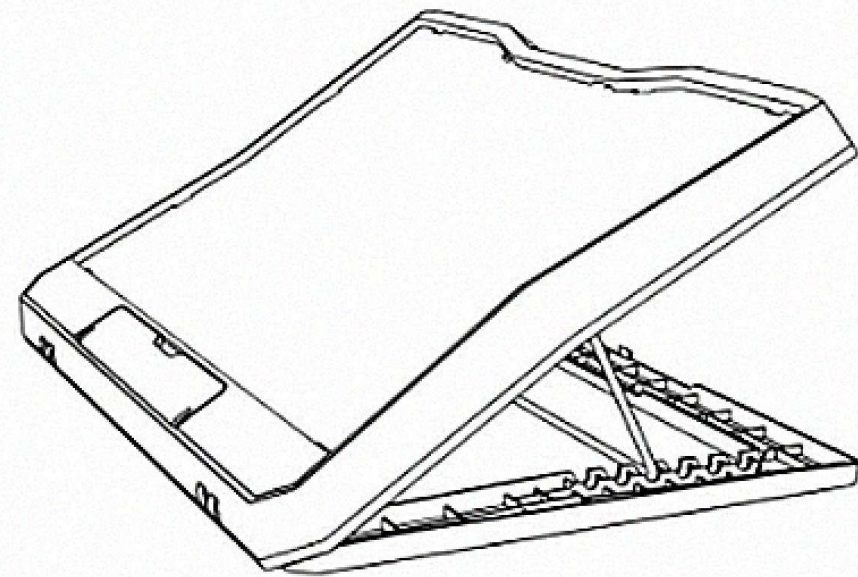

Laptop-Kühlpad

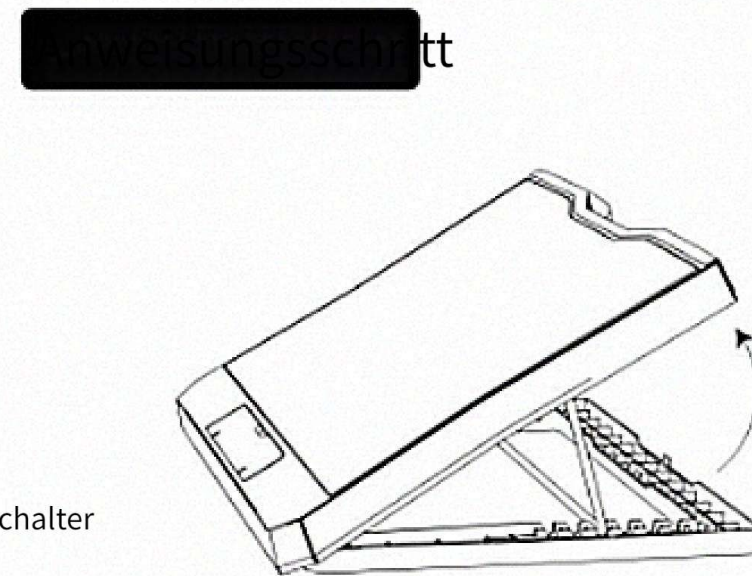
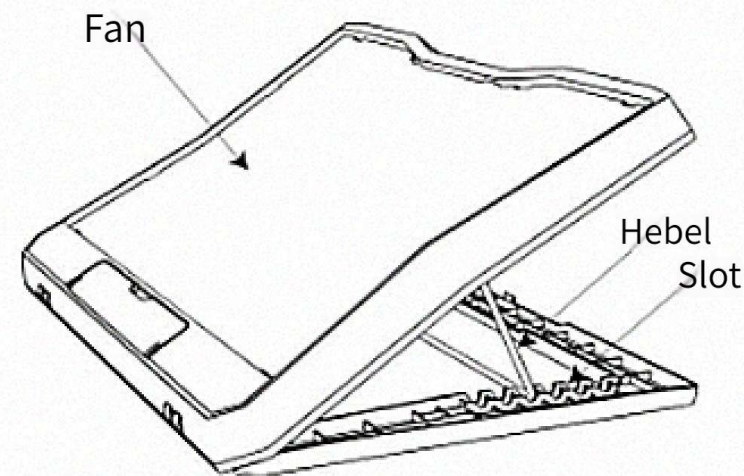
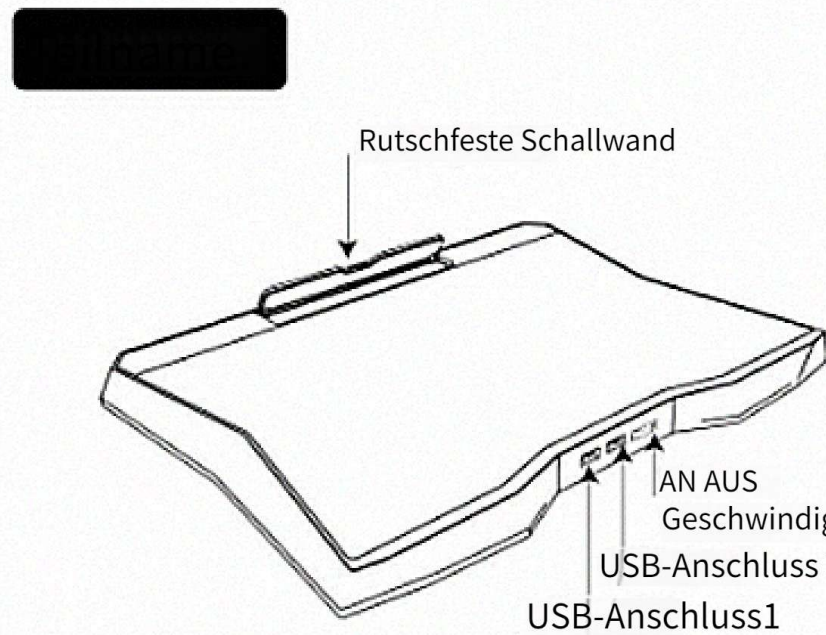

1. Öffnen Sie die Basis und stellen Sie den Hebel auf die bequemste Position ein. 6 verschiedene Höheneinstellungen für den Bedarf des Benutzers an besseren Betrachtungswinkeln.

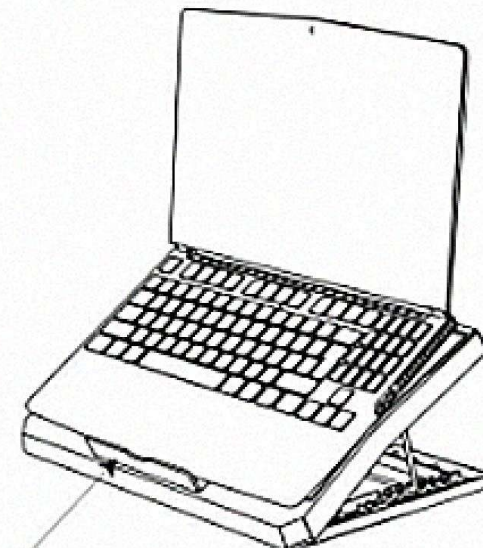

2. Öffnen Sie die Anti-Rutsch-Schallwand an der Vorderseite. Legen Sie Ihren Laptop oder Tablet-PC auf das Kühlpad.

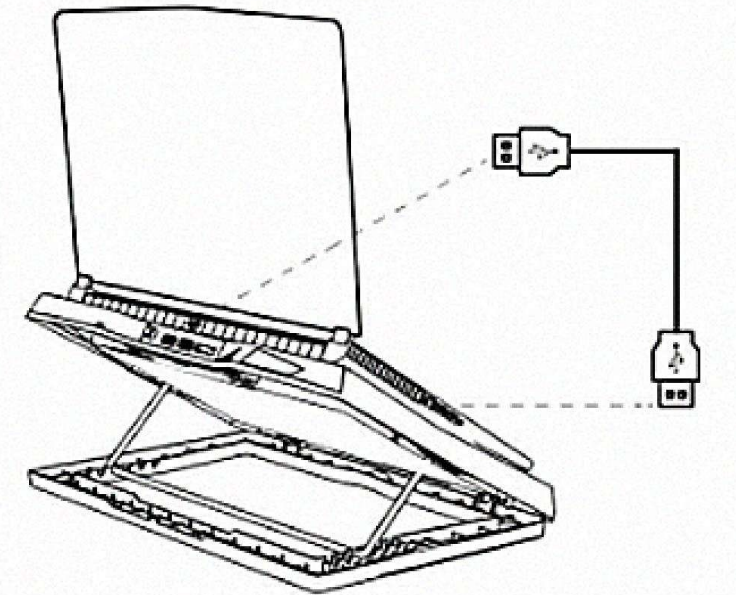

3. Schalten Sie Ihren Laptop oder Tablet-PC ein. Verbinden Sie das USB-Kabel mit dem Gerät und dem USB-Anschluss auf der Rückseite des Kühlpads.

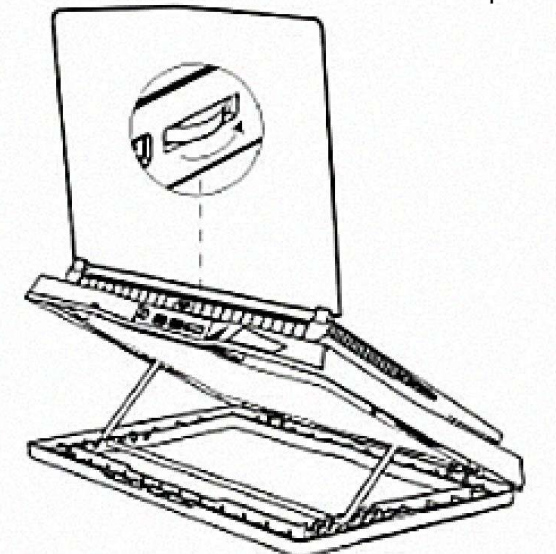

4. Schalten Sie Ihr Kühlpad mit dem Lüftergeschwindigkeits-Drehesalter ein und passen Sie die Lüftergeschwindigkeit an. (Hinweis: Drehen Sie nach links, um sie zu verringern. Drehen Sie nach rechts, um sie zu erhöhen.)

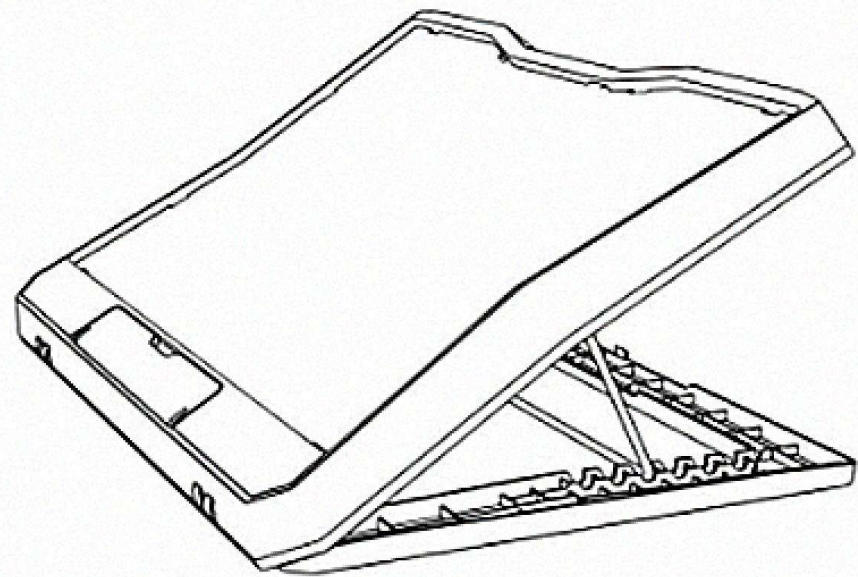

ide

Coussin de refroidissement pour ordinateur portable

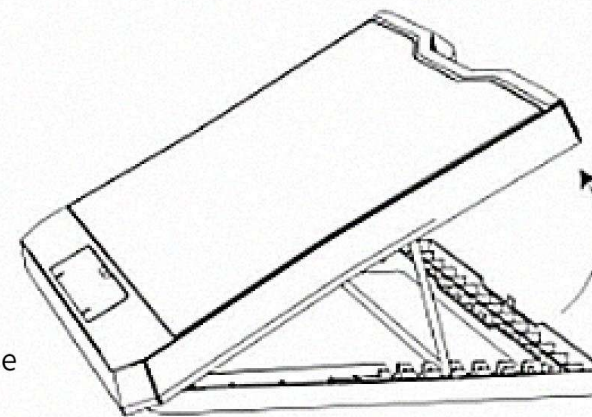
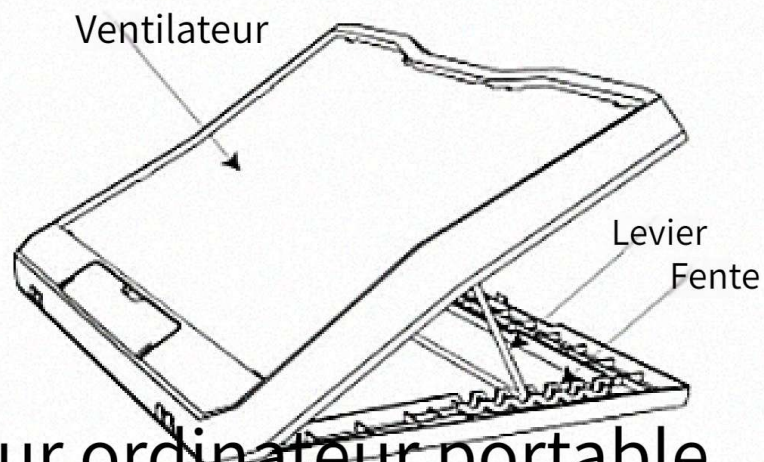
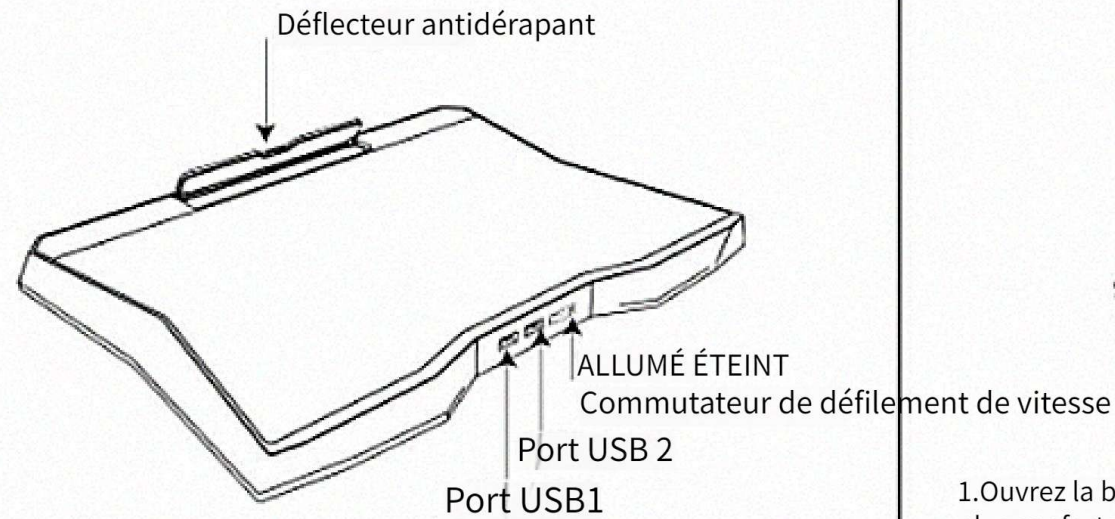

1. Ouvrez la base, ajustez le levier à la position la plus confortable. 6 réglages de hauteur différents pour répondre aux besoins de l'utilisateur en matière d'angles de vision plus larges.

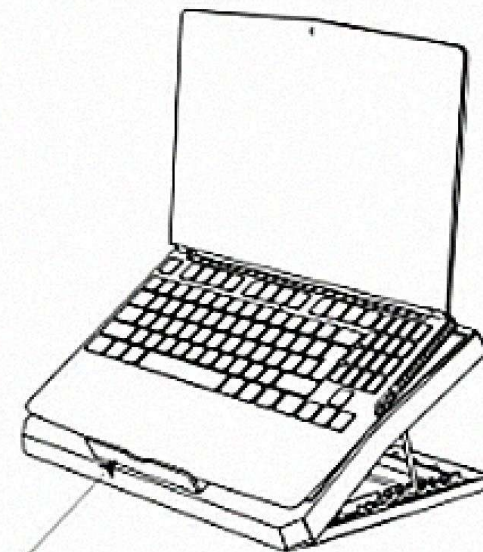

2. Ouvrez le déflecteur antidérapant sur le devant. Placez votre ordinateur portable ou votre tablette sur le tapis de refroidissement.

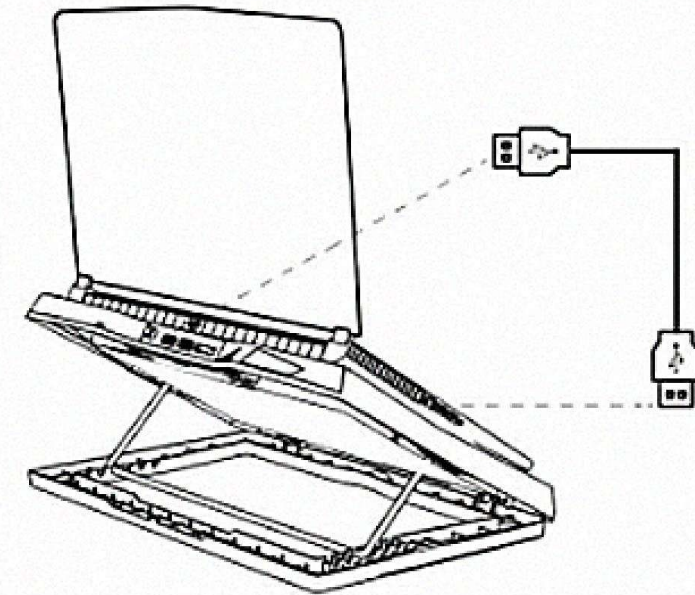

3. Allumez votre ordinateur portable ou votre tablette PC. Connectez le câble USB à l'appareil et au port USB situé à l'arrière du coussin de refroidissement.

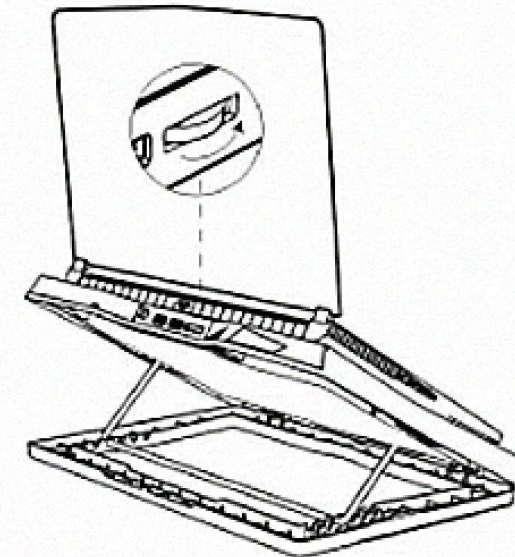

4. Utilisez le commutateur de défilement de la vitesse du ventilateur pour allumer votre coussin de refroidissement et régler la vitesse des ventilateurs. (Non : tournez vers la gauche pour diminuer. Tournez vers la droite pour augmenter)

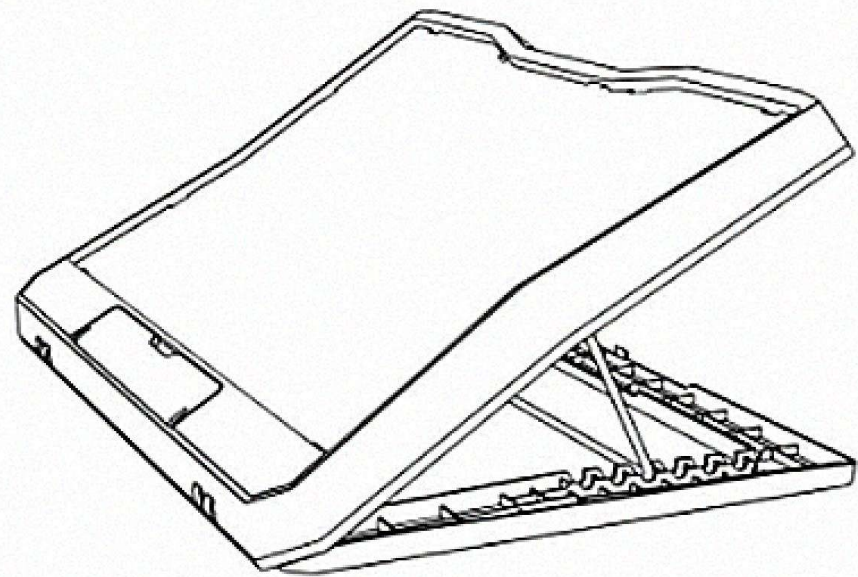

ノートパソコン冷却パッド

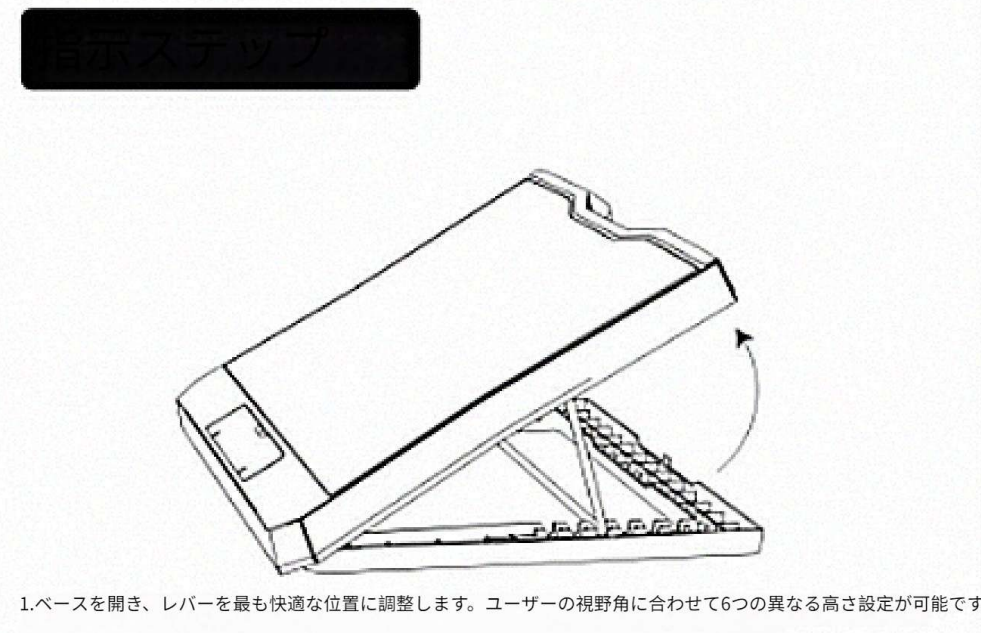
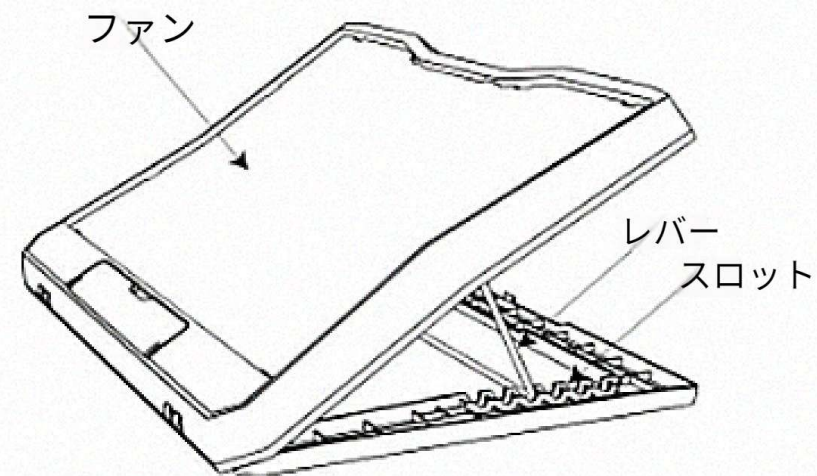
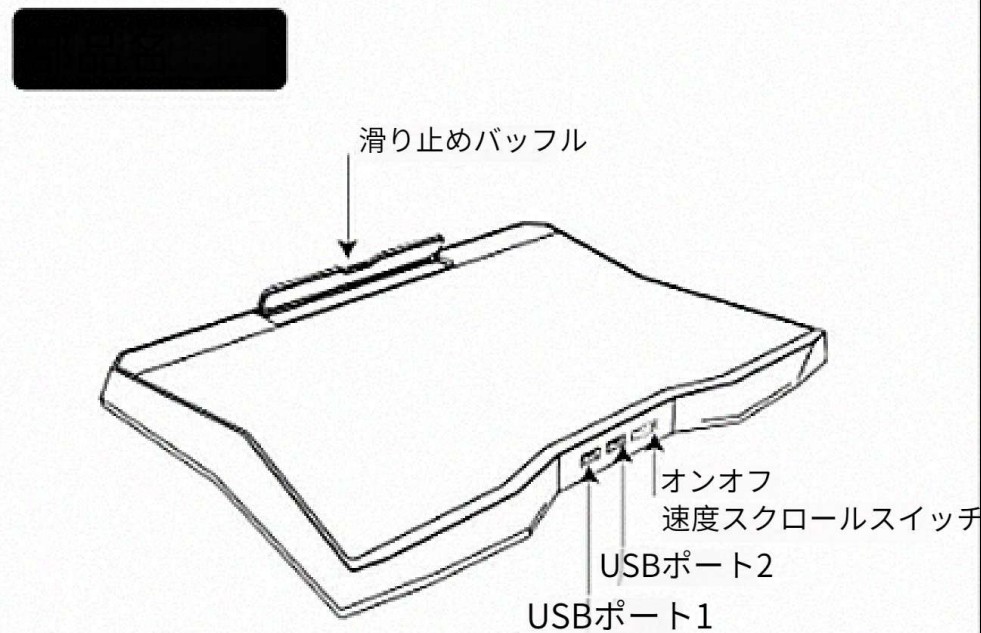

1. ベースを開き、レバーを最も快適な位置に調整します。ユーザーの視野角に合わせて6つの異なる高さ設定が可能です。

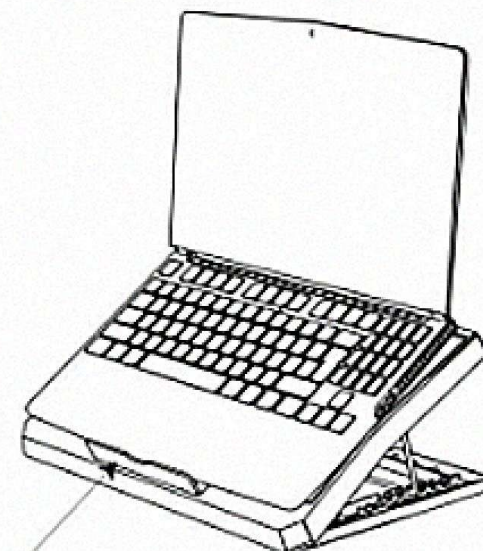

2. 前面の滑り止めバッフルを開き、ラップトップまたはタブレット PC を冷却パッドの上に置きます。

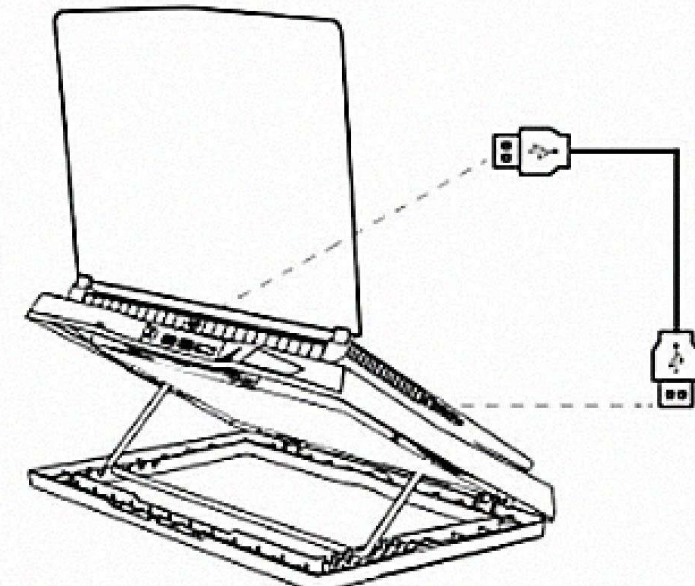

3. ノートパソコンまたはタブレット PC の電源を入れます。USBケーブルをデバイスと冷却パッドの背面にある USB ポートに接続します。

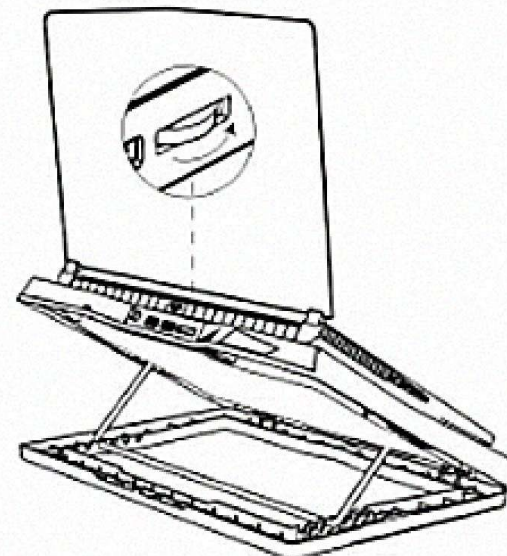

4. ファン速度スクロールスイッチを使用して冷却パッドをオンにし、ファンの速度を調整します。(No. 左に回すと速度が下がり、右に回すと速度が上がります)

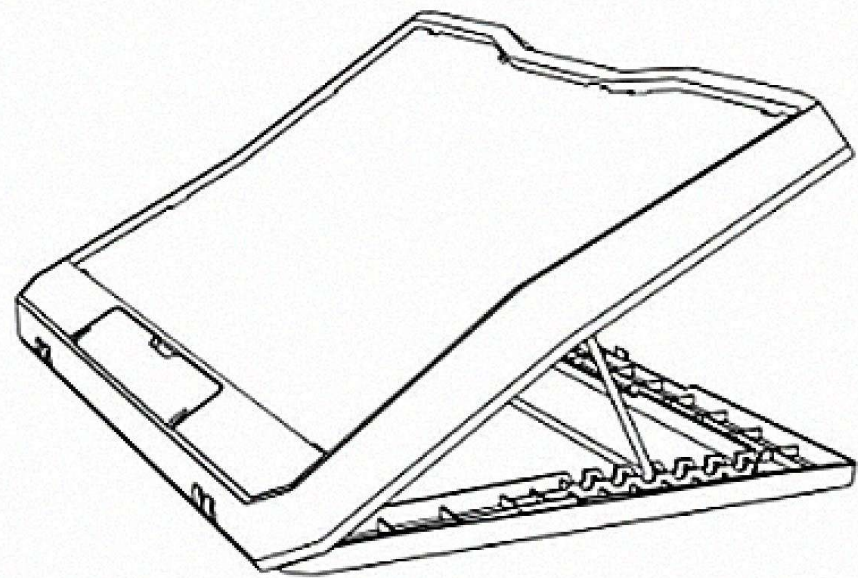

Pad di raffreddamento per computer portatile



parte

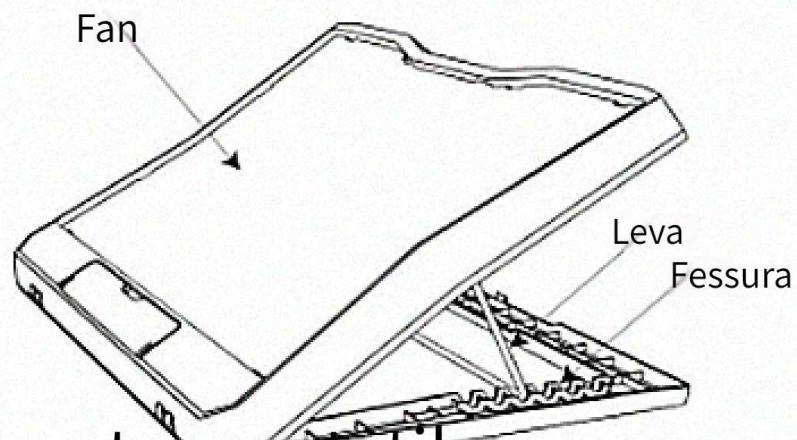
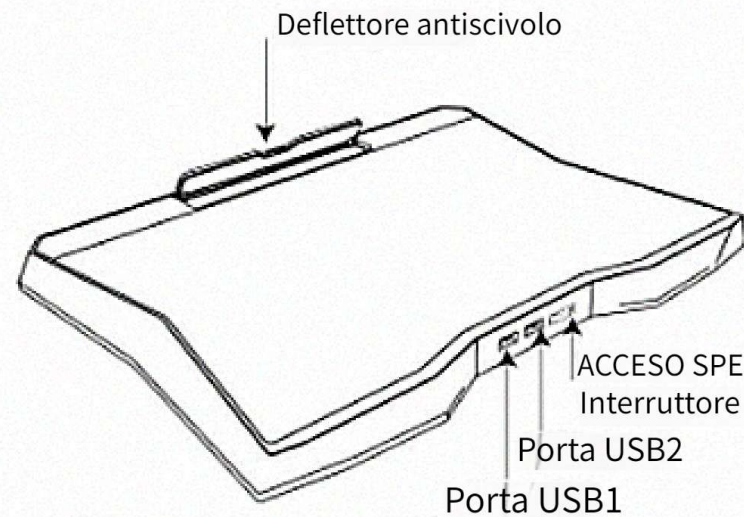

modalità di istruzioni

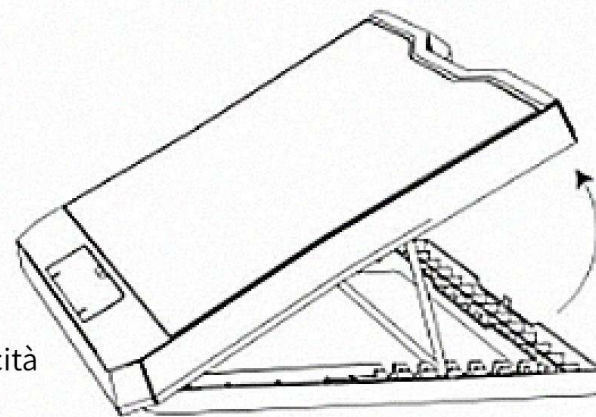

1. Aprire la base, regolare la leva nella posizione più comoda. 6 diverse impostazioni di altezza per soddisfare le esigenze dell'utente per angoli di visione migliori.

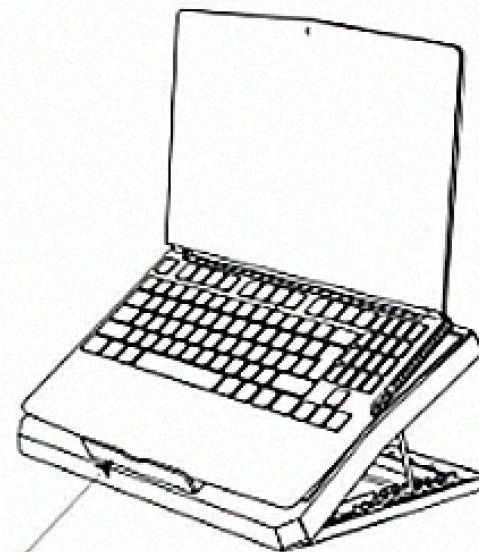

2. Aprire il deflettore antiscivolo sulla parte anteriore. Posizionare il laptop o il tablet PC sul supporto di raffreddamento.

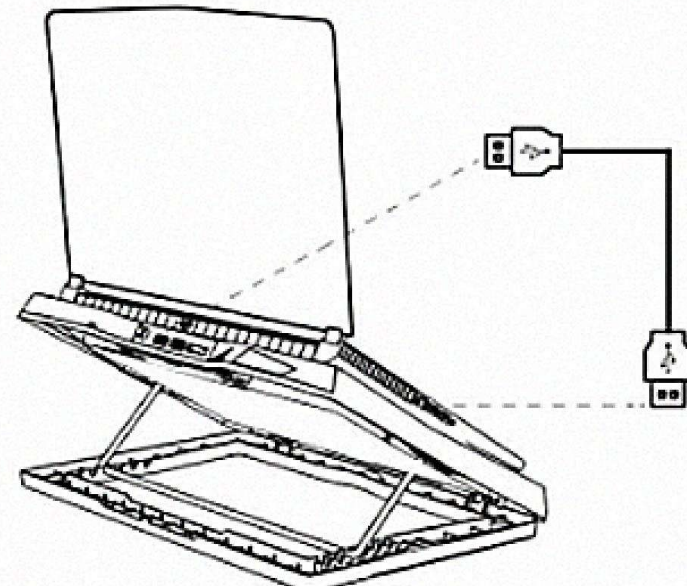

3. Accendi il tuo laptop o tablet PC. Collega il cavo USB al dispositivo e alla porta USB situata sul retro del pad di raffreddamento.

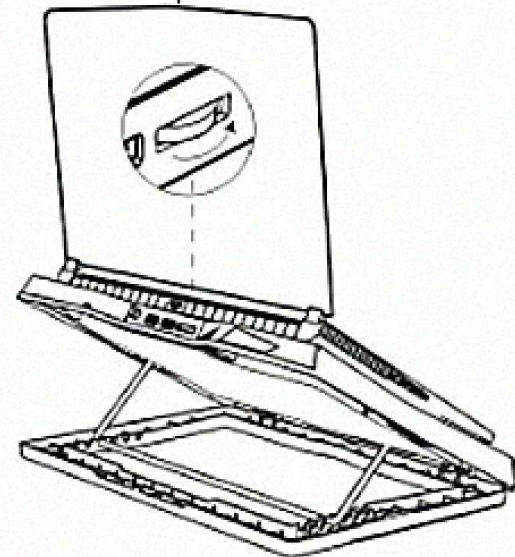

4. Utilizzare l'interruttore di scorrimento della velocità della ventola per accendere il tappetino di raffreddamento e regolare la velocità delle ventole. (Nota: ruotare verso sinistra per diminuire. Ruotare verso destra per aumentare)

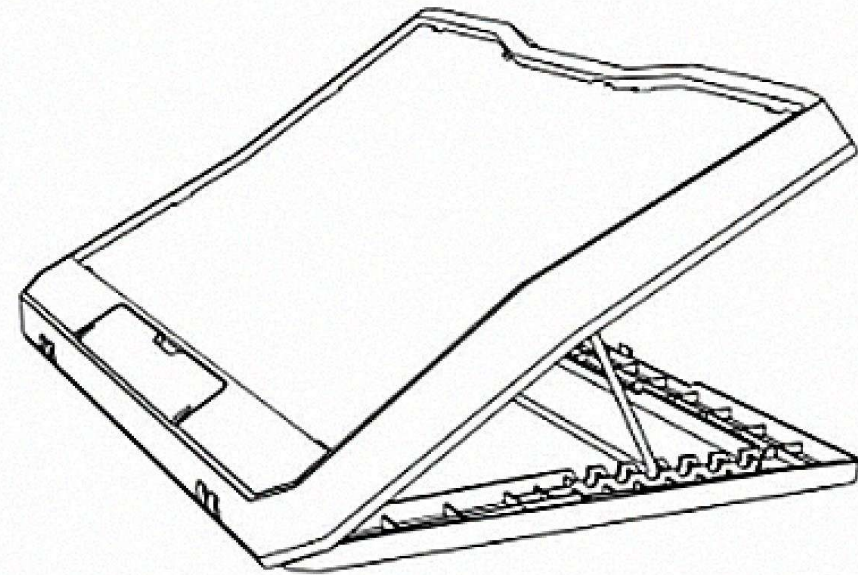

노트북 냉각 패드

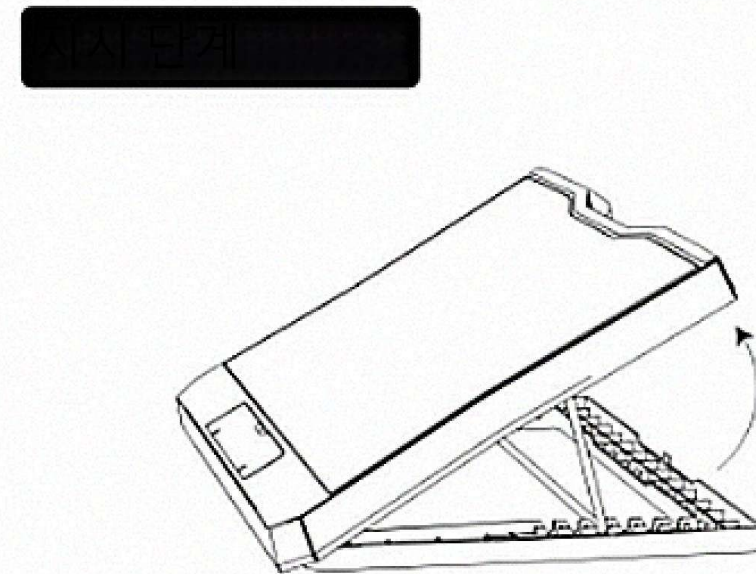
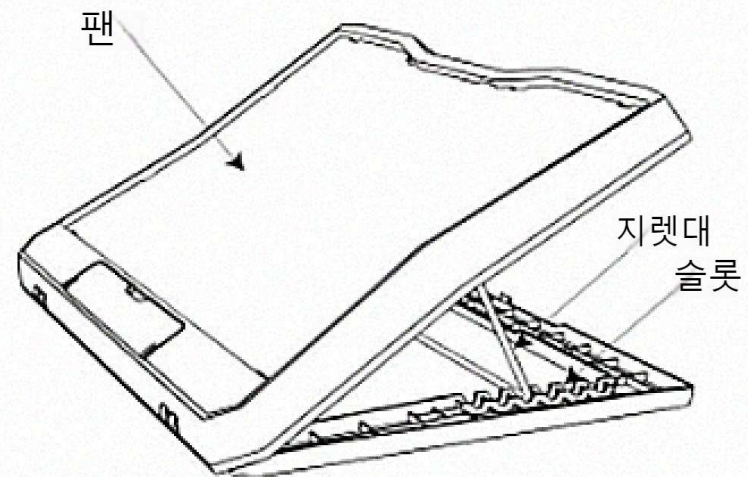
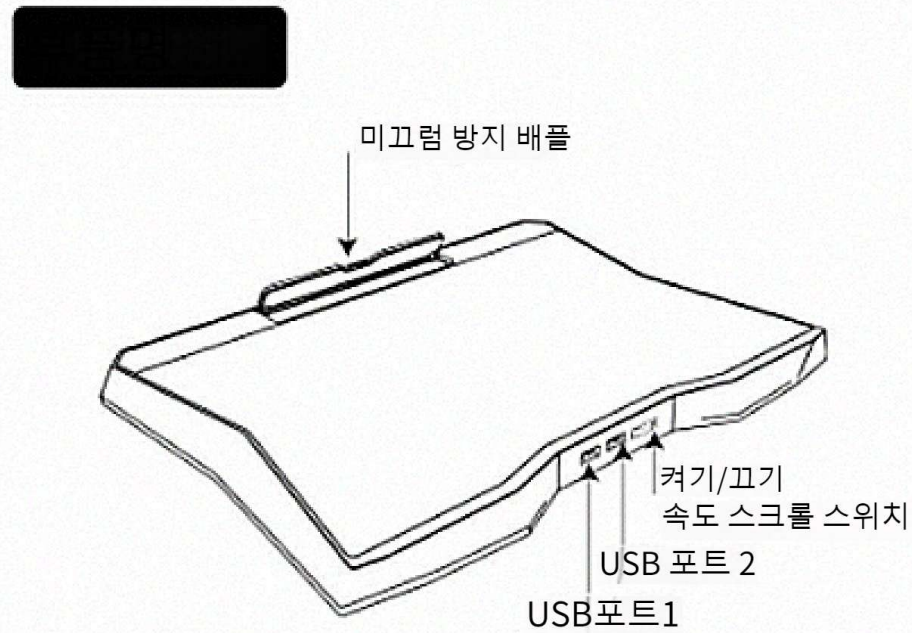

1. 받침대를 열고 가장 편안한 위치로 레버를 조정합니다. 사용자의 시야각을 더 좋게 하기 위한 6가지 높이 설정

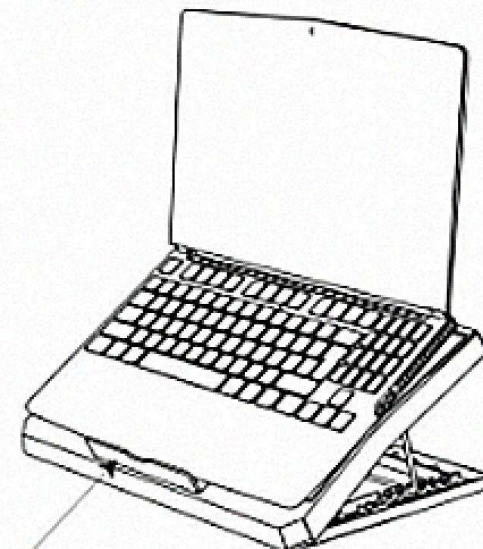

2. 전면의 미끄럼 방지 배플을 엽니다. 노트북이나 태블릿 PC를 쿨링 패드 위에 올려 놓습니다.

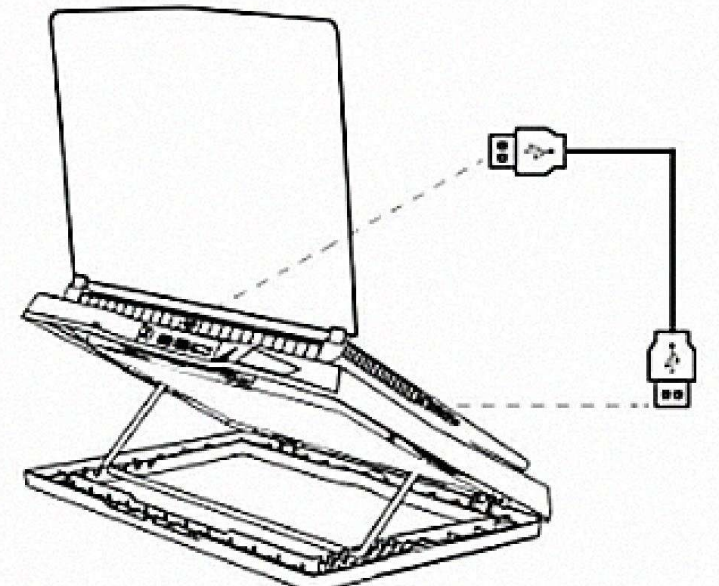

3. 노트북이나 태블릿 PC를 켭니다. USB 케이블을 장치와 쿨링 패드 뒷면에 있는 USB 포트에 연결합니다.

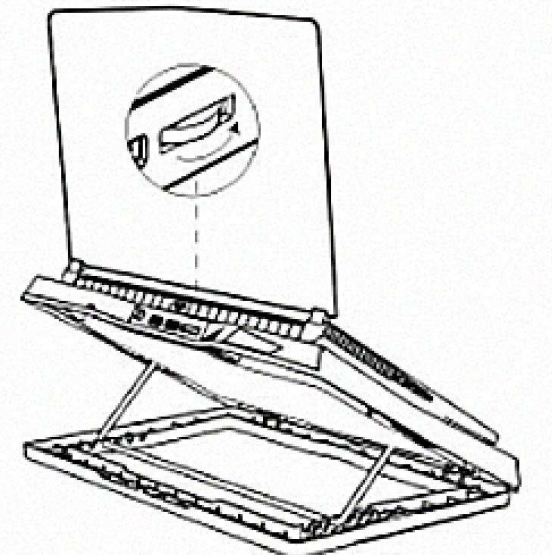

4. 팬 속도 스크롤 스위치를 사용하여 쿨링 패드를 켜고 팬 속도를 조절합니다. (Note: 왼쪽으로 돌리면 감소하고 오른쪽으로 돌리면 증가합니다.)

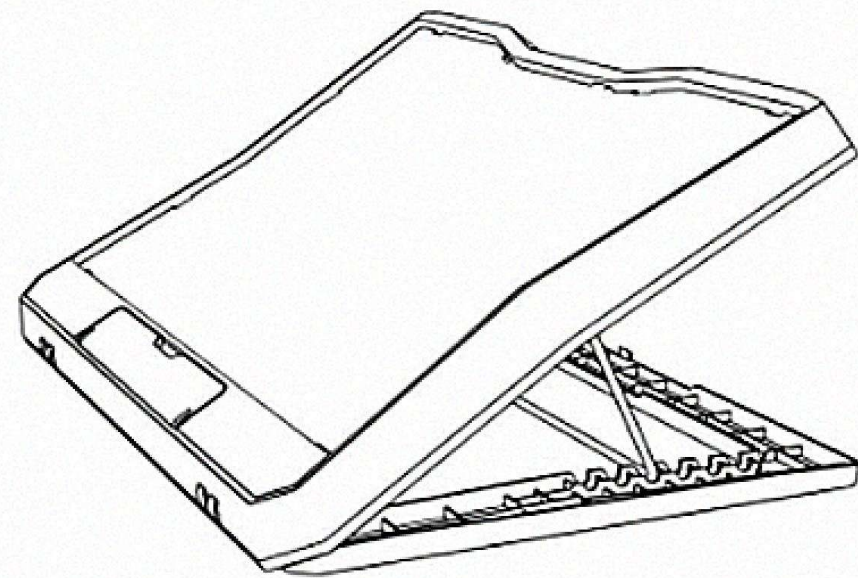

Kylplatta för bärbar dator

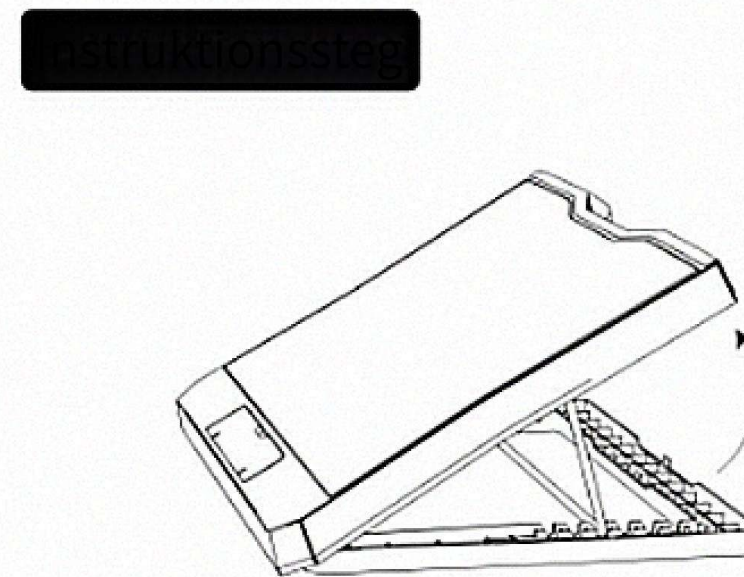
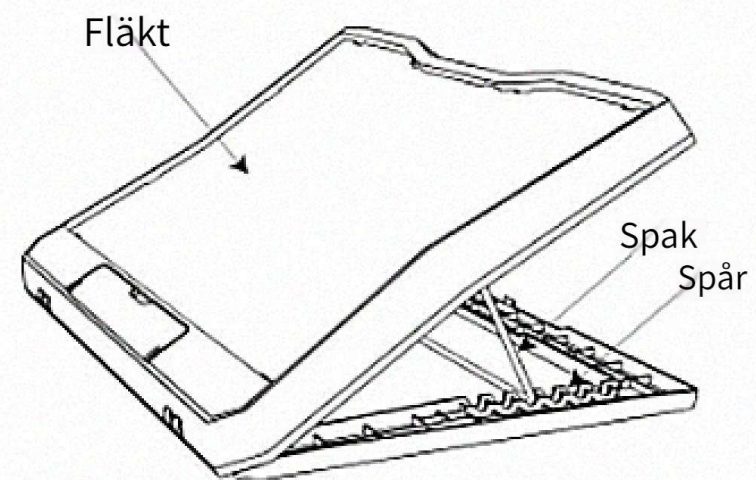
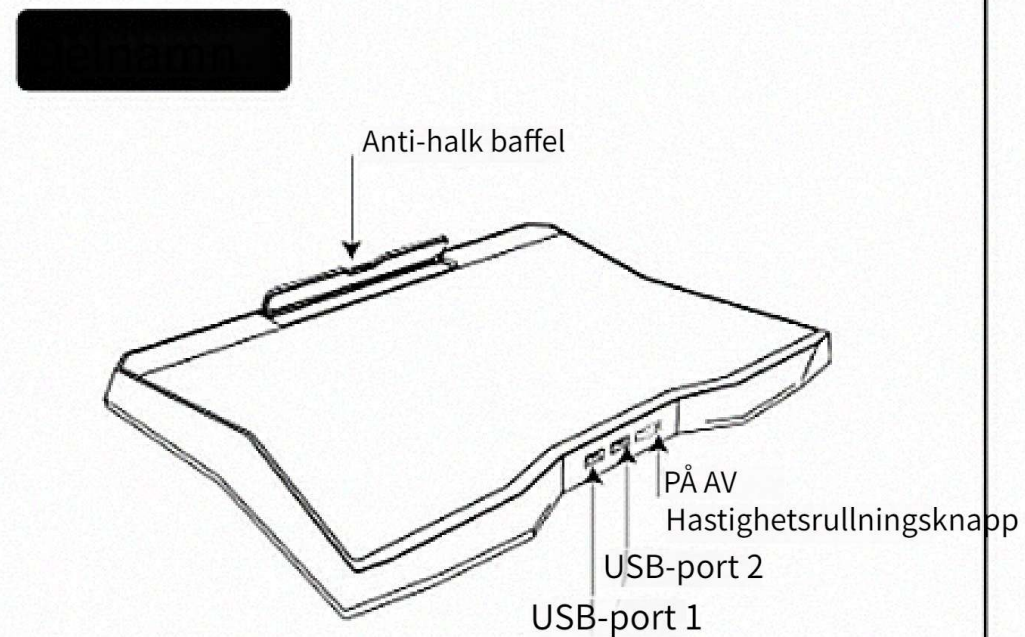

1. Öppna basen, spänn spaken till det mest bekväma läget.
6 olika höjdställningar för användarens krav på bättre betraktningvinklar

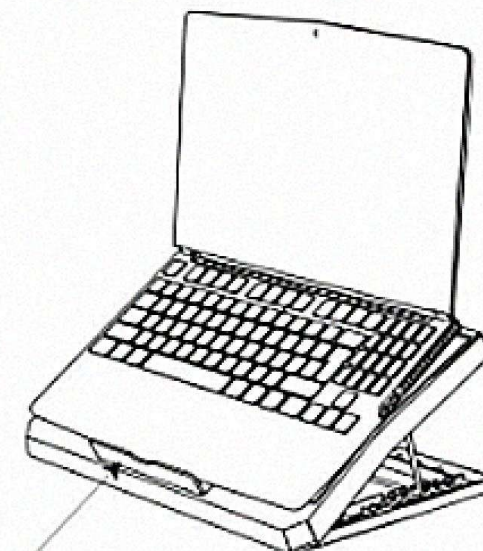

2. Öppna halkskyddet på framsidan. Placera din bärbara dator eller surfplatta på kylplattan.

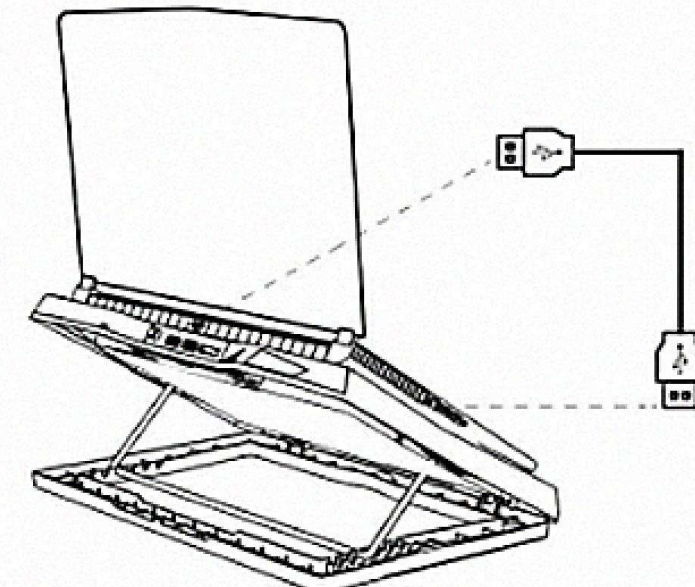

3. Slå på din bärbara eller surfplatta. Anslut USB-kabeln till device och USB-porten på baksidan av kylplattan

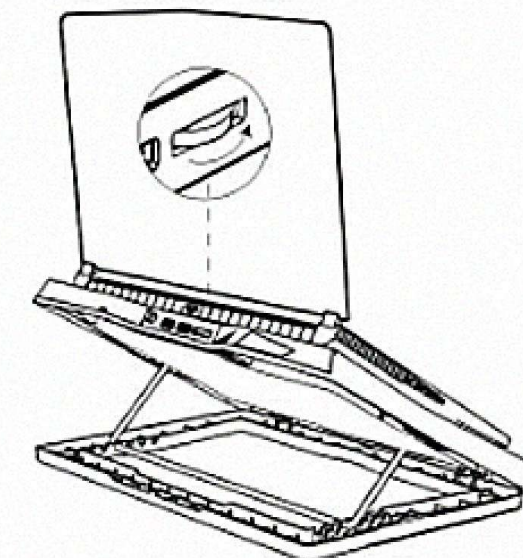

4. Använd rullningsknappen för fläkthastighet för att slå på kylplattan och justera hastigheten på fläktarna. (Nolo: Vrid till left lo minskning, tum åt höger för att öka)

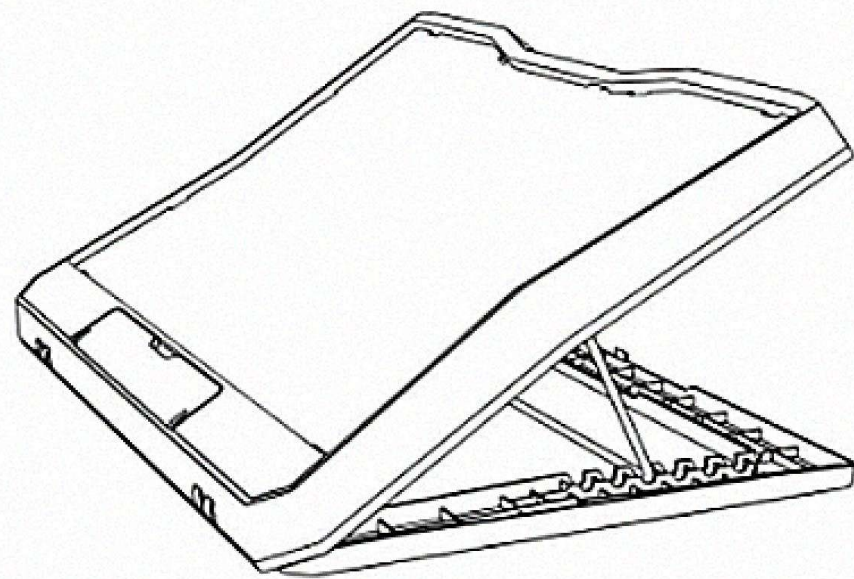

Chladicí podložka pod notebook

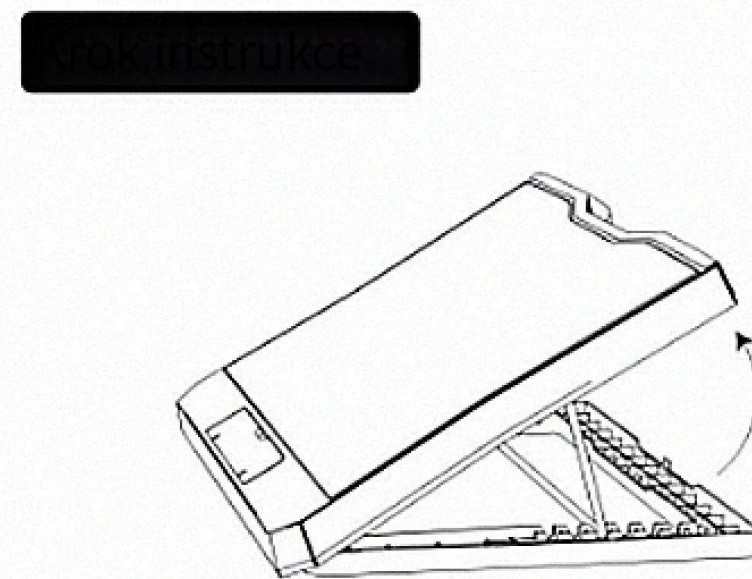
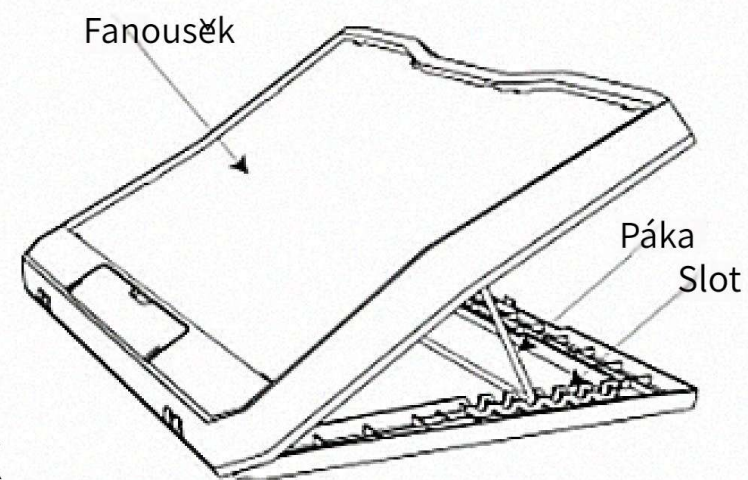
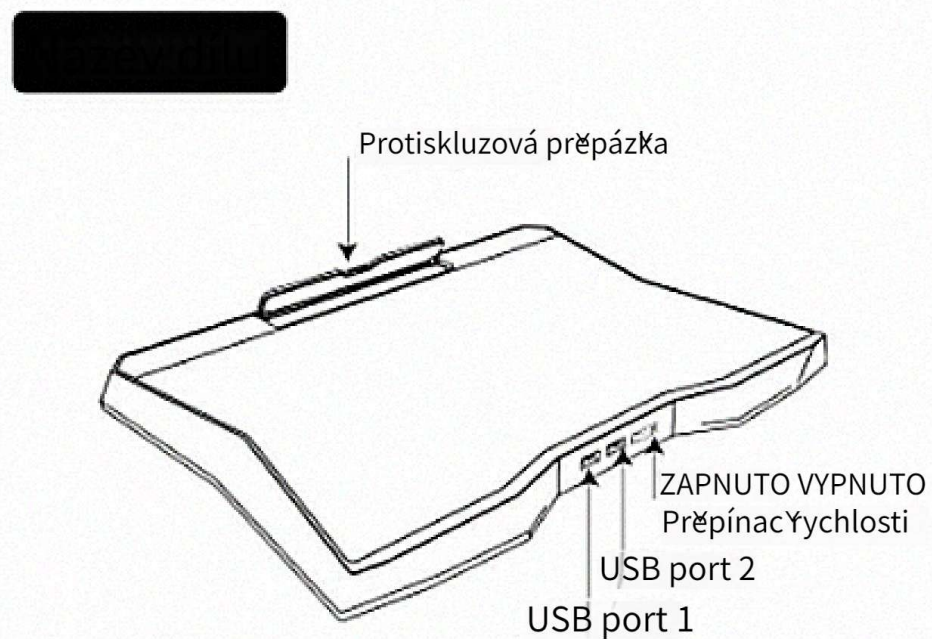

1. Otevřete základnu, nastavovací páčku do nejpohodnější polohy. 6 různých nastavení výšky pro požadavky uživatele na lepší pozorovací úhly

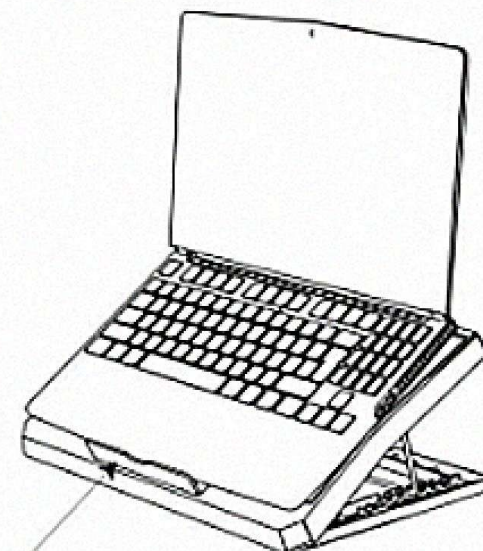

2. Otevřete protiskluzovou přepážku na přední straně. Položte svůj notebook nebo tablet PC na chladicí podložku.

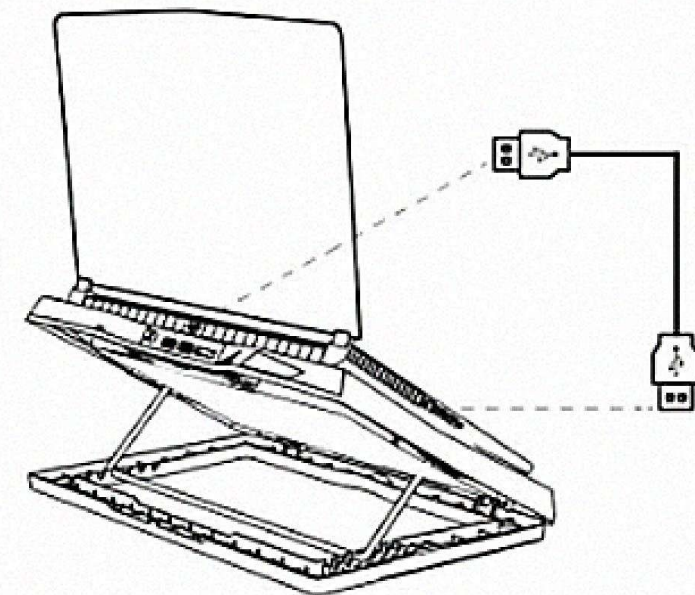

3. Zapněte svůj notebook nebo tablet PC. Připojte kabel USB k zařízení a portu USB umístěnému na zadní straně chladicí podložky

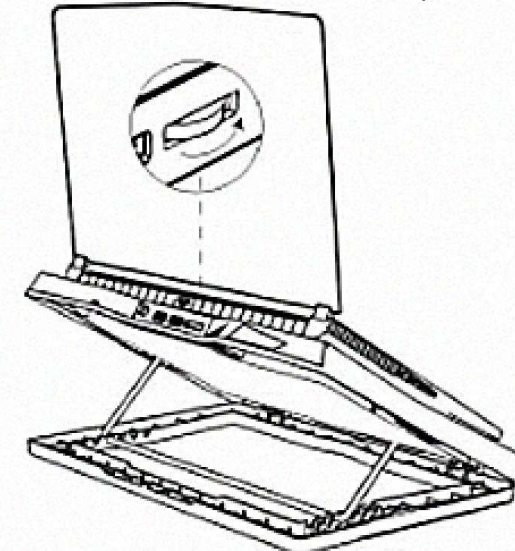

4. Pomocí posuvného spínače rychlosti ventilátoru zapněte chladicí podložku a upravte rychlost ventilátorů. (Nolo: Otočením doleva lo snížením. Tím doprava zvýšíte)

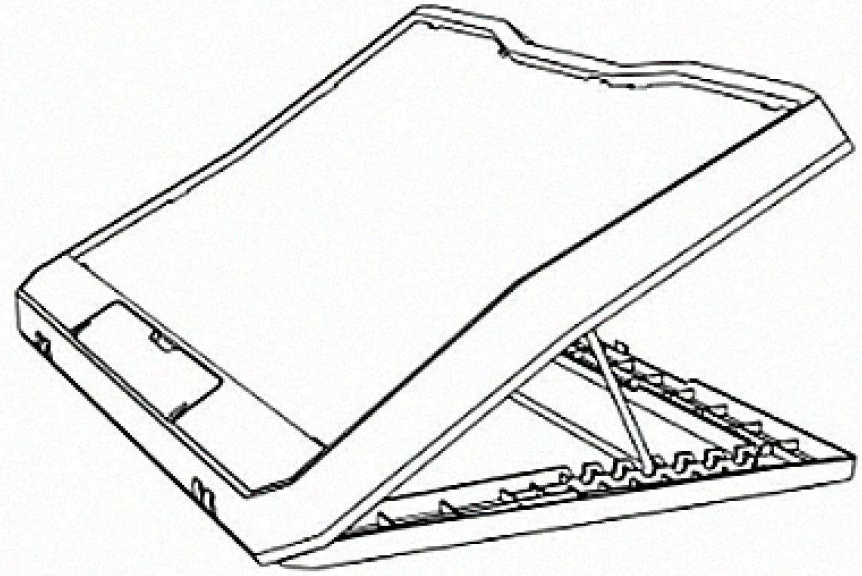

وسادة تبريد الكمبيوتر المحمول

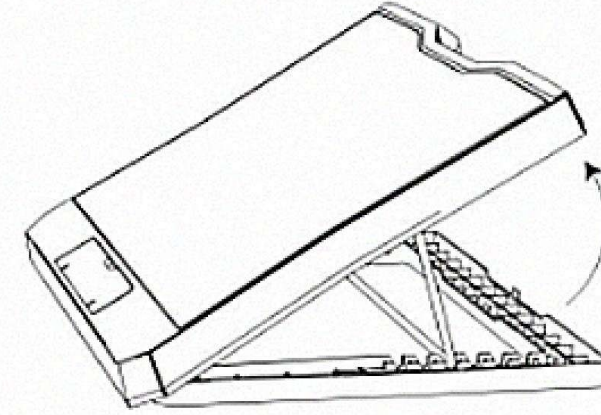
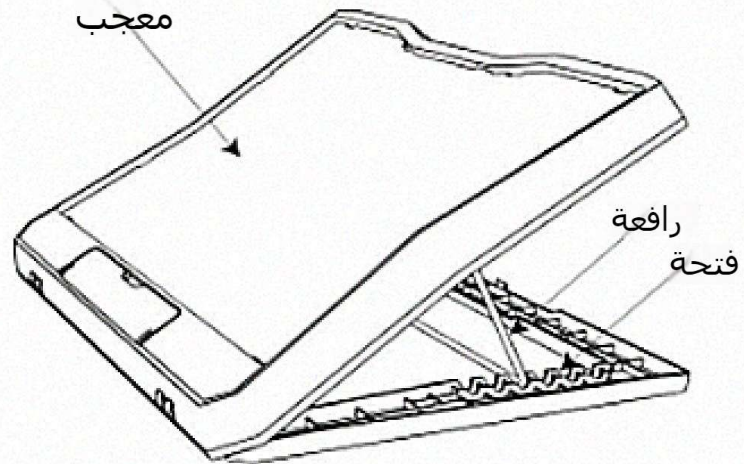
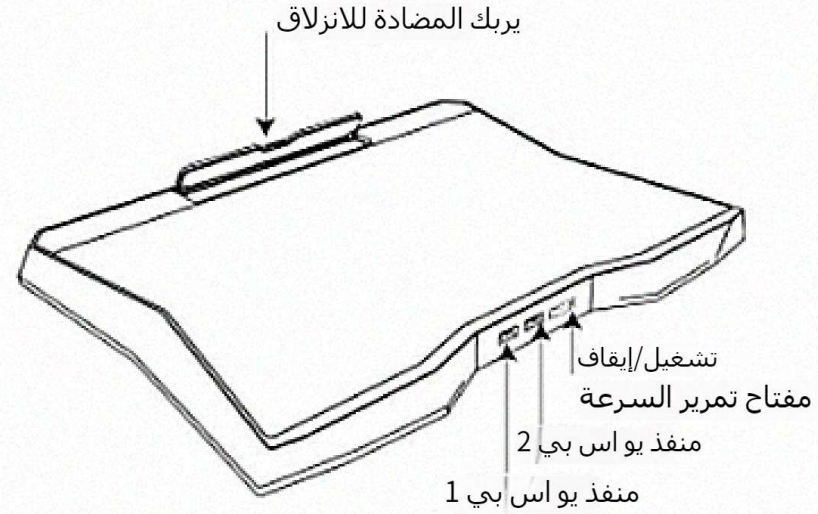

1. افتح القاعدة، وذراع التعديل إلى الوضع الأكثر راحة. 6 إعدادات ارتفاع مختلفة لتلبية متطلبات المستخدم للحصول على زاوية رؤية أفضل

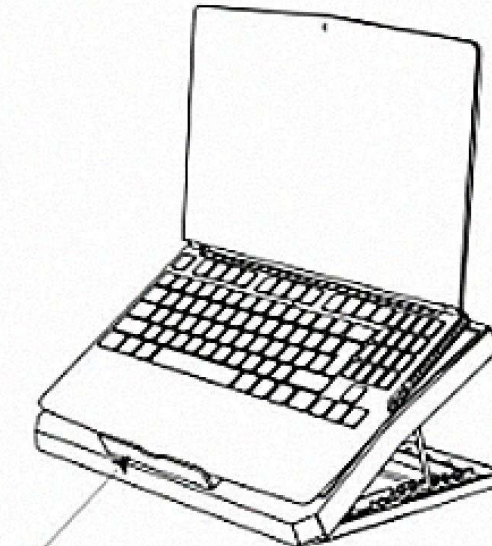

2. افتح الحاجز المضاد للانزلاق في المقدمة. ضع الكمبيوتر المحمول أو الكمبيوتر اللوحي على وسادة التبريد.

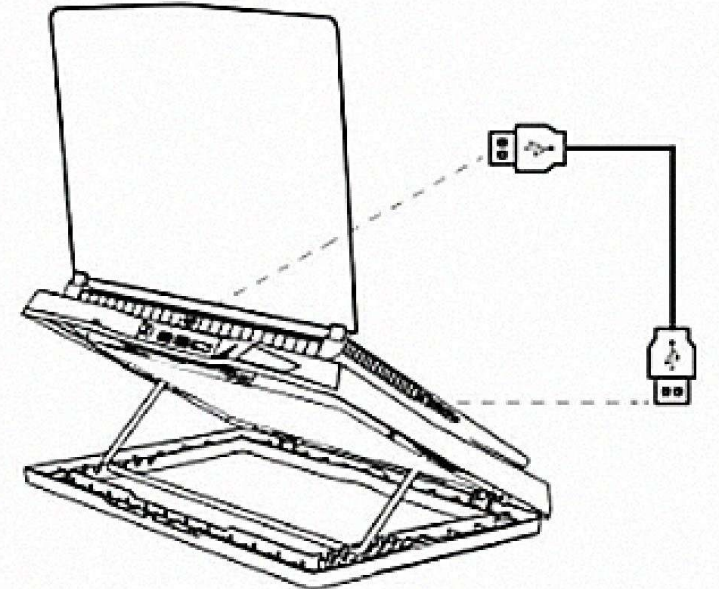

3. قم بتشغيل الكمبيوتر المحمول أو الكمبيوتر اللوحي. قم بتوصيل كابل USB بالجهاز ومنفذ USB الموجود في الجزء الخلفي من لوحة التبريد

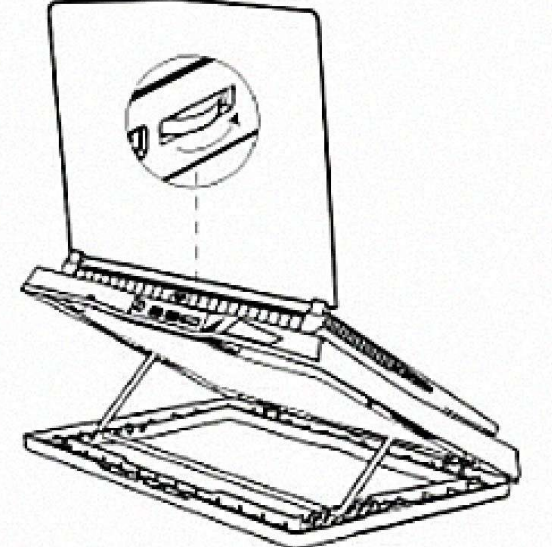

4. استخدم مفتاح تمرير سرعة المروحة لتشغيل وسادة التبريد وضبط سرعة المراوح (لا: أدر إلى اليسار لتقليل السرعة، أدر إلى اليمين لزيادة السرعة)

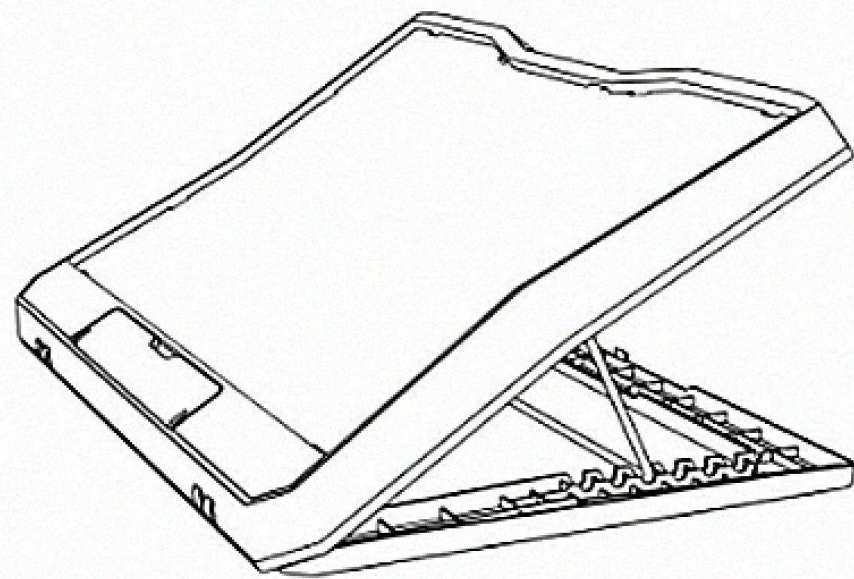

Podkładka chłodząca do laptopa

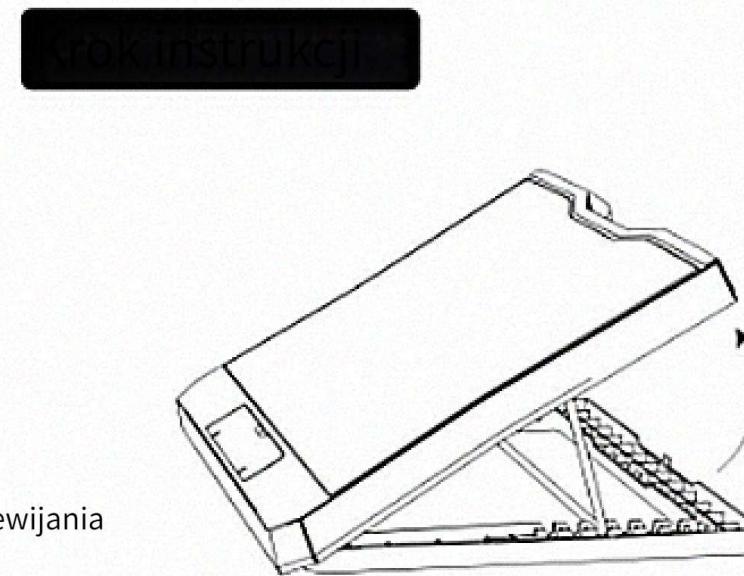
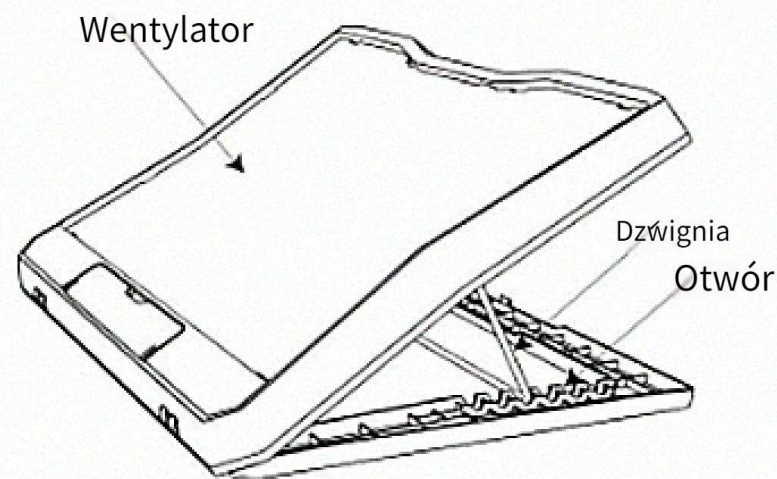
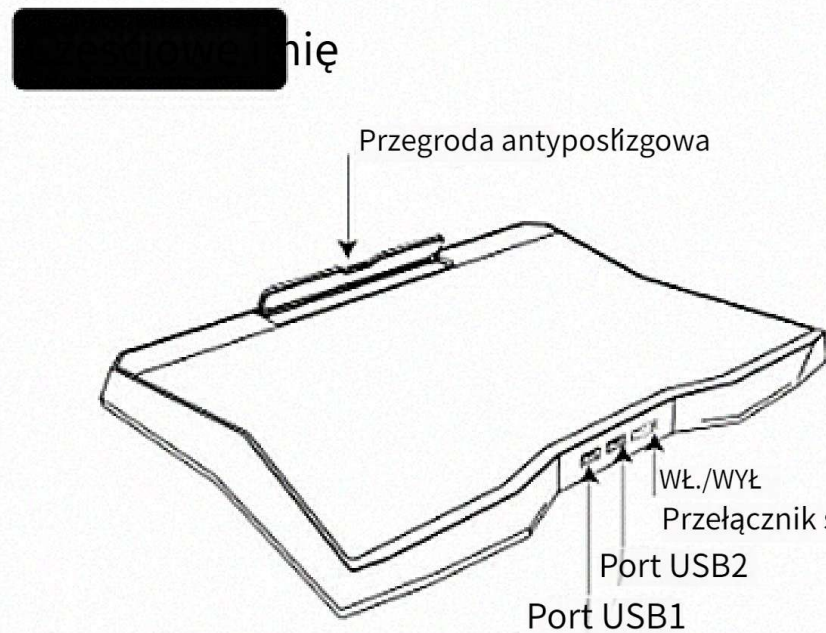

1. Otwórz podstawę, ustaw dzwignię w najwygodniejszej pozycji. 6 różnych ustawień wysokości pozwala użytkownikowi na uzyskanie lepszych kątów widzenia.

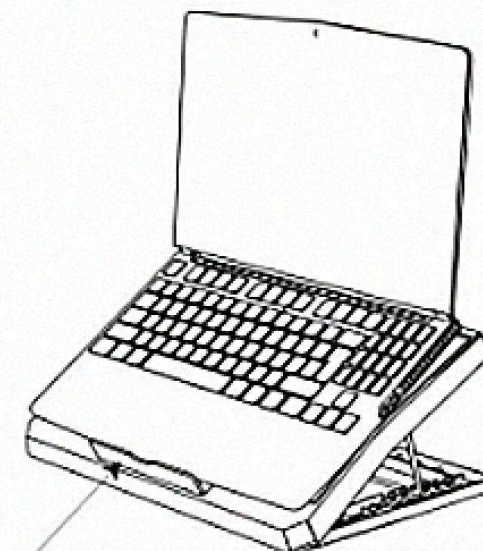

2. Otwórz przegrodę antypoślizgową z przodu. Połóż laptopa lub tablet na podkładce chłodzącej.

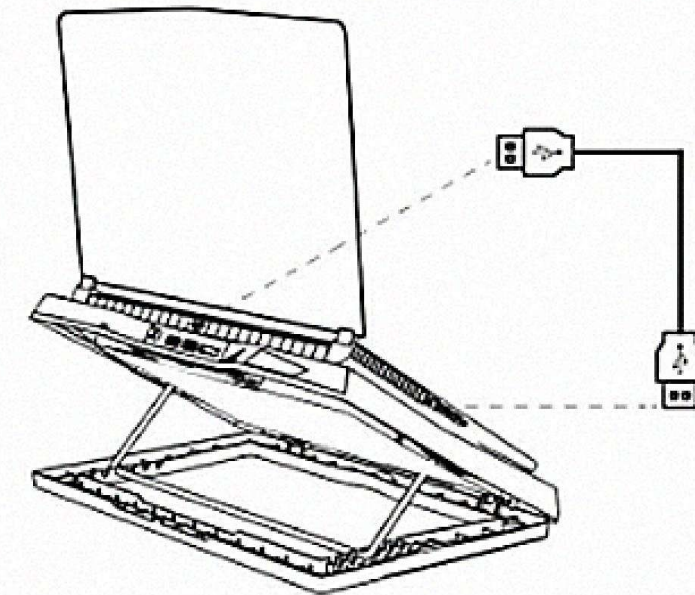

3. Włącz laptop lub tablet. Podłącz kabel USB do urządzenia i portu USB znajdującego się z tyłu podstawki chłodzącej.

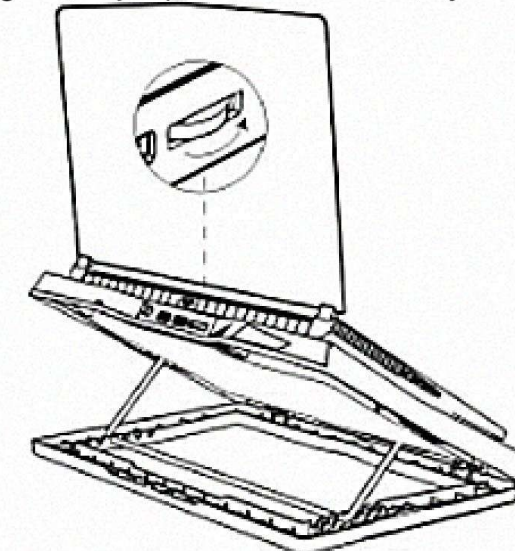

4. Użyj przełącznika prędkości wentylatora, aby włączyć podkładkę chłodzącą i dostosować prędkość wentylatorów. (Nie: Przekręć w lewo, aby zmniejszyć prędkość; Przekręć w prawo, aby ją zwiększyć)

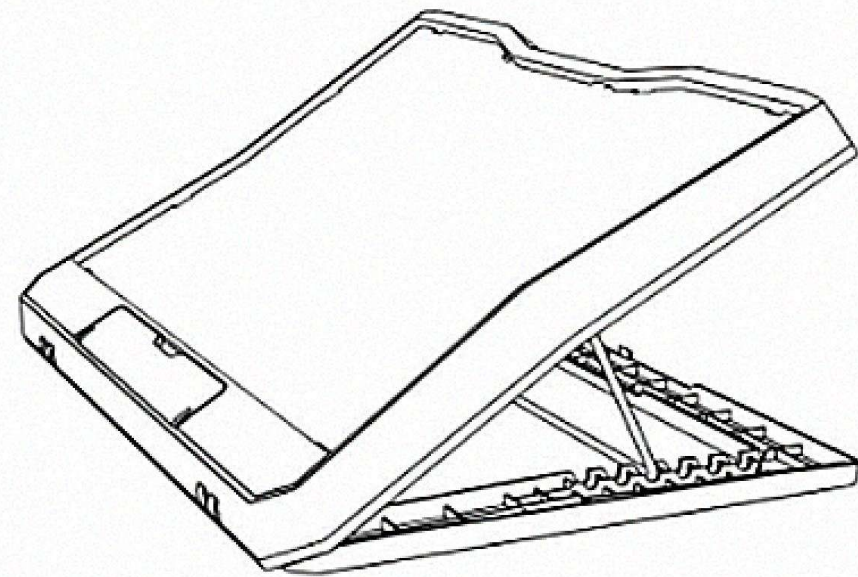

Koelkussen voor laptops

naam

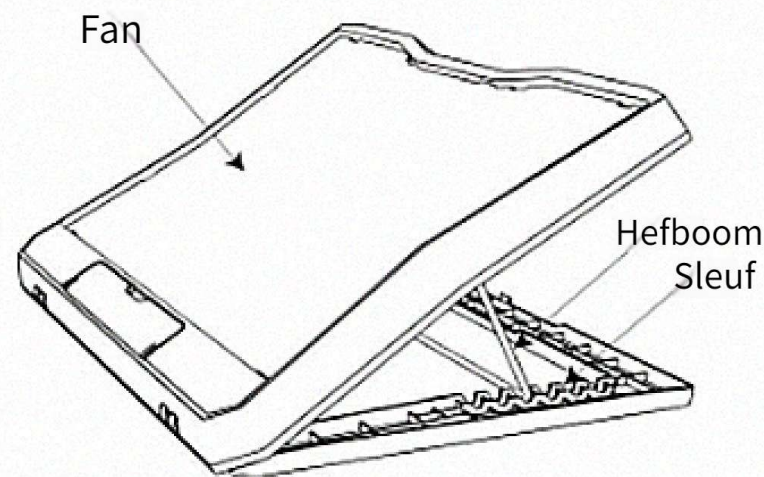
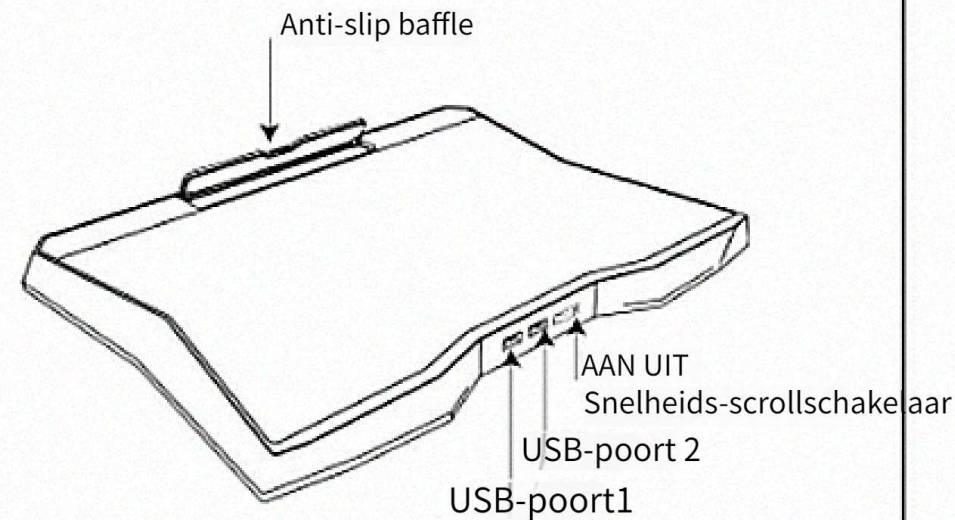

Stap

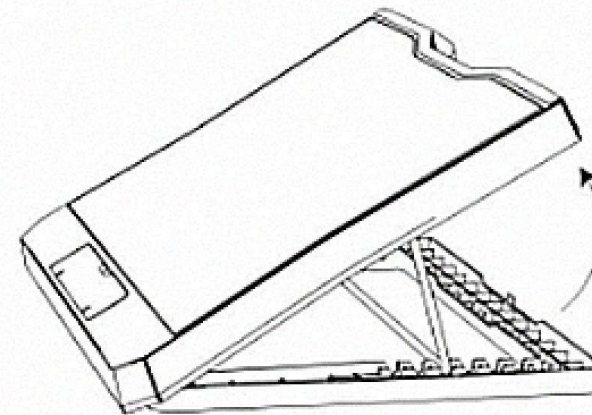

1. Open de basis, stel de hendel in op de meest comfortabele positie. 6 verschillende hoogte-instellingen voor de behoefte van de gebruiker aan betere kijkhoeken

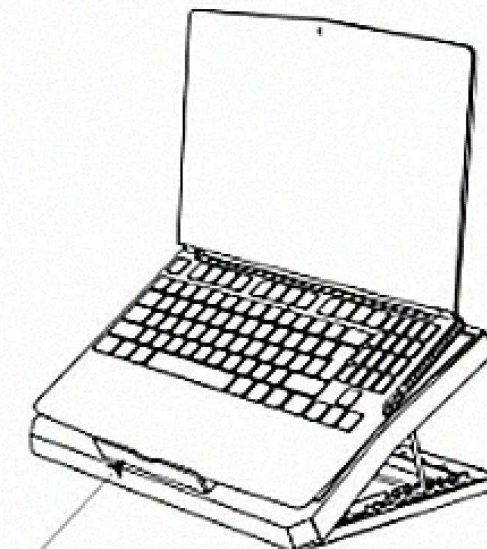

2. Open het antislipschot aan de voorkant. Plaats uw laptop of tablet-pc op het koelkussen.

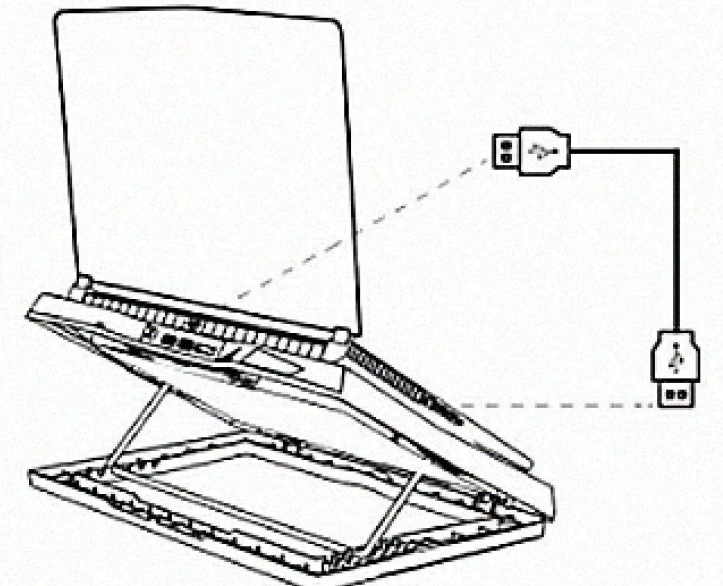

3. Schakel uw laptop of tablet-pc in. Sluit de USB-kabel aan op het apparaat en de USB-poort aan de achterkant van de koelmat.

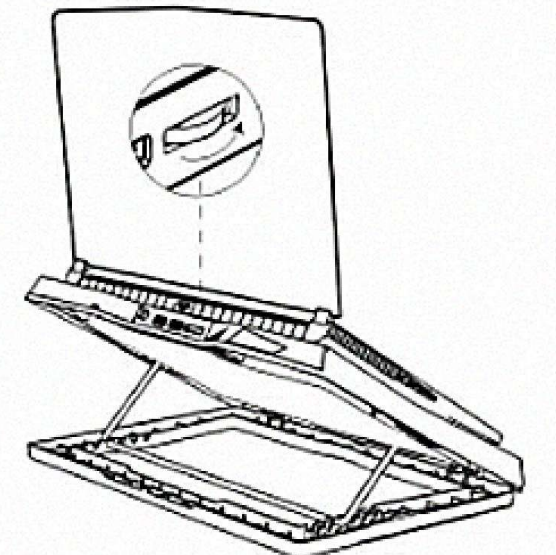

4. Gebruik de schuifknop voor de ventilatorsnelheid om uw koelmat in te schakelen en de snelheid van de ventilatoren aan te passen. (Noto: draai naar links om te verlagen, draai naar rechts om te verhogen)